

Order No.: V3009
Description: **WS1 Auxiliary
Microswitch Assembly**

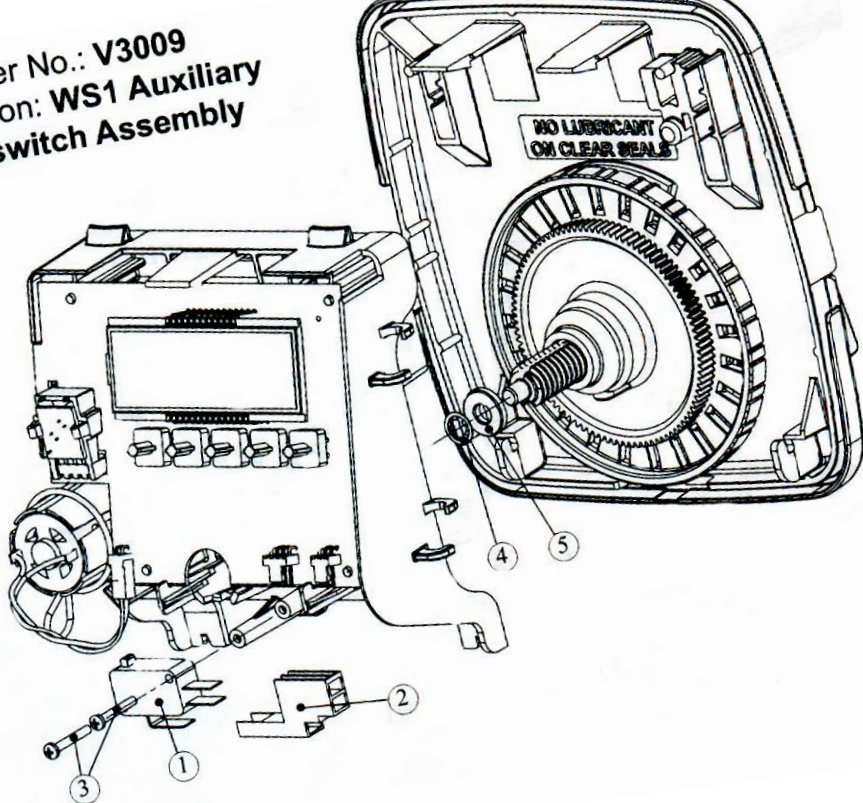

ДЕЛАЕМ ЧИСТУЮ
ВОДУ ДОСТУПНОЙ!



Order No.: **V3009**

Description: **WS1 Auxiliary Microswitch Assembly**

Drawing No.	Order No.	Description	Quantity
1	V3301	WS1 MICROSWITCH	1
2	V3302	WS1 MOLEX CONNECTOR	1
Not shown	V3303	WS1 MOLEX TERMINAL	3
3	V3304	WS1 SCREWS 4/40X3/4	2
4	V3305	WS1 RETAINING RING SS 1/4	1
5	V3306	WS1 WASHER ID 0.257 OD 0.640	1

Slip the washer and retaining ring on to the end of the piston rod. Attach the microswitch to the drive bracket using the screws. Attach the connector to the microswitch. Attach the terminals to wires and connect.